

Issue 1/2002

**EDITORIAL**

Dear Reader,

There have been a number of changes since the last issue of this newsletter.

**We have moved!!**

Only three kilometers, to be sure—and literally within sight of our previous location—but still an important step for PI.

The Production, Engineering and Purchasing Departments have been working at the new site since July. Sales, Development and Administration joined them in the last week of October.

Thanks to the best of preparations and the dedication of our staff, the move went so smoothly that you, our customers, probably did not even notice.

Now with more room, new measurement and testing facilities, more personnel and even higher motivation, we are there to serve you from our new headquarters in Karlsruhe.

Our new buildings are right on the A8 Autobahn, exit No. 42 (Karlsruhe), where you are more than welcome to visit us.

Sincerely,  
Dr. Karl Spanner  
President

**Microstage fits just about anywhere – the new M-110 / M-111**

In the past, travel range in the millimeter range with sub-micron resolution in a compact package was a recipe for trouble, at the very least when it came to motorizing the system. The new M-110 and M-111 micro-stages make this a thing of the past. This generation of motorized translators offers travel ranges from 5 to 15 mm in a package measuring only 62 x 60(70) x 20 mm. In closed-loop operation, the DC motor achieves speeds of up to 2.5 mm/s, minimal incremental motion of 0.05 µm and guiding accuracy of 1 µm. The central aperture in the platform and the XY, XZ and XYZ combinations make the system suitable for a wide range of applications.

M-110 / M-111 microstages with the specifications described above are ideal for use in photonics packaging, fiber positioning, quality control, and anywhere where precision positioning in tight quarters is required. In combination with PI's C-842 or C-844 controllers, or with the new C-880 multi-axis controller, the compact microstages offer inexpensive entry into the field of automated fiber positioning. Where higher resolutions are required, systems with piezoelectric drives can be added, such as the NanoCube seen in the picture.



**M-110 / M-111 Microstages in industrial applications**

Do you have  
High duty-cycles?  
24-hour operation?  
7 days/week, 365 days/year?  
If the M-110 / M-111 looks like it would fit in your setup, then consider the version with low-friction recirculating ballscrew.  
Call and discuss your application with a PI sales engineer.

**Piezo Motor Kick-Off**

PI has been working on piezo-electric motor development for a long time. Now we are able to introduce two products:

**PiezoMike**

The PiezoMike is a non-rotating-tip micrometer driven directly by a piezoelectric rotary motor. The unit is controlled via a manual control pad.

- Advantages of the piezo motor design:
- Direct drive with no gearing
  - High holding force when powered off
  - Excellent start/stop behavior
  - Smooth and quiet motion
  - No magnetic fields.

The piezo motors can execute steps of about 0.5 µm as easily as continuous motion at up to 2 mm/s. Because the PiezoMike is an open-loop system, it is more suited to applications involving rapid, remote-controlled adjustments than for high reproducibility.

Turning the micrometer spindle manually at any time is also permissible. And if you happen to run into the hard stop, no problem! Just back off in the other direction.

PiezoMike—a robust and easy-to-use adjusting tool, with travel ranges of 10, 25 and 50 mm.

**Translation stage with integrated piezo linear-motor drive**

You may have seen this unit at LASER 2001 in Munich. Its main trump lies in its compatibility with PI motor controllers.

There are big differences in the mechanics: no drive spindle, enabling a much flatter design, different control behavior and all the characteristics that set piezo motors apart. But you can use the same proven PI motor controllers as with other PI stages. The stage has the same linear scale encoder as the other more common PI stages. To achieve this compatibility you simply connect the small included converter box between the controller and the stage.

The maximum speed of 50 mm/s is currently limited by the controller. It should soon be possible to increase this to 200 mm/s.

In the coming months, PI will be integrating piezo motors into other stages, some specially designed to fit the motor and others reflecting current, well-known stage geometries.

**The smallest piezo motor**

The adjacent illustration shows the prototype of a piezoelectric rotary motor with a through shaft and a diameter of **only 3 mm!!** The motor is planned for application as a drive unit in micro-systems technology. The prototype shown can provide a torques of up to 0.4 millinewton meters.

Customer-specific problems in which limited space makes conventional solutions inappropriate will increasingly result in new developments being introduced.

**We are willing and able to solve your problems. We have all the required components under our control, from the piezoelectric ceramics, the electronics and the working principles, protected by our own patents.**

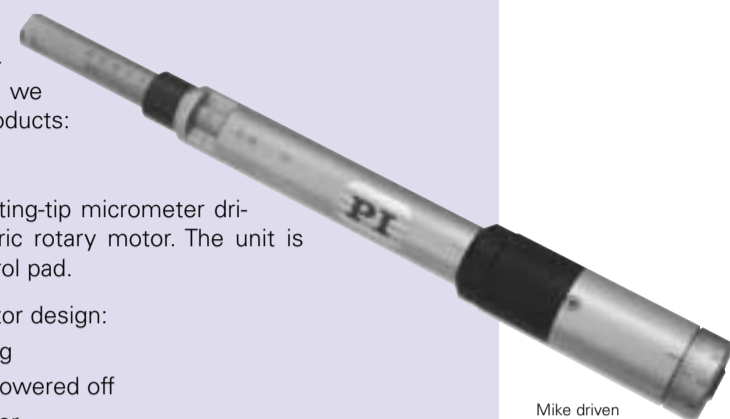

Mike driven by piezoelectric rotary motor

**CATALOG CATALOG**

The new PI catalog, *MicroPositioning, NanoPositioning, NanoAutomation, Solutions for Cutting-Edge Technologies* is now available. In addition to the comprehensive product information familiar from previous editions, the new work features an application-oriented approach which will make it easier to find the product group that fits your needs. Just click on the new catalog on our homepage (www.pi.ws) or order your free printed copy today. Spend some time just browsing through the 400 pages in 9 sections. The catalog is currently available in English only, but a German version is in preparation.

The best catalog or Internet presentation, however, can never replace a talk with one of our representatives about your particular situation. A large portion of our sales are to OEMs, and many are products customized to meet special requirements.

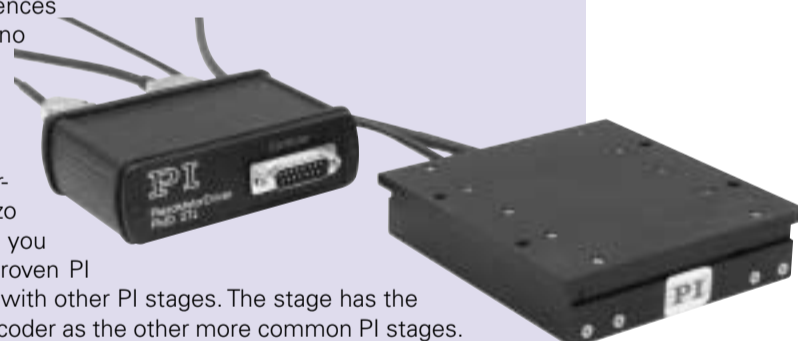

M-665.2PM Linear translator with 50 mm travel range, piezoelectric linear drive and adaptor box for use with standard PI motor controllers



Miniature piezoelectric rotary motor.

**P-611 Nanocube™**

The successful NanoCube™ series of XYZ NanoPositioners has been widened to include several new versions.

By its compact design, 100 µm travel range in 3 axes and high resolution, the P-611 NanoCube™ has found rapid acceptance for the most varied of positioning tasks in fiber optics and photonics packaging. To better meet the specialized requirements in the fiber-optics area, models with integrated fiber holder interface are being offered. The P-611.3SF and P-611.3OF allow direct mounting of the P-603.xx fiber, objective and waveguide holders. A model for highest flexibility with a crossed fiber holder interface is planned.



NanoCube™. Compact XYZ NanoAlignment system with 100 µm travel range in each axis and 1 nm resolution, shown here with the P-603.22 fiber-holder ferrule. For more information on this product, see pages 2-36 and 8-18 in our 2001 catalog or visit www.pi.ws

The different compatible controllers, such as the PC card (E-760), the desktop E-664.S3 and the modular E-500-series electronics, allow easy adaptation of the piezo system to the most varied of requirements. With the E-760 PC-card and the F-206 fiber-coupling Hexapod or C-880 controller, the P-611 NanoCube™ becomes a multi-axis positioning system with long travel ranges and resolution in the nanometer range.

**Vacuum Versions**

High-resolution electron microscopy is finding more and more use in quality control and research applications. Here there is need for high-resolution positioners capable of vacuum operation. The P-611 NanoCube™ is thus available in a vacuum-compatible version for pressures down to 10<sup>-6</sup> hPa. For processes where magnetic properties play a role, PI also offers versions made completely of non-magnetic materials.

**New Stepper-Motor Controller: C-600**

PI's C-600 stepper-motor controller opens a new dimension in precision positioning and trajectory control. This 4-axis controller was specially developed for automation tasks, precision measurements and general positioning in both research and industrial settings. Resolution of up to 20,000 steps per revolution make sub-micron accuracy and path control possible.



Technical Data	
Function	Desktop stepper-motor controller
Axes	4
Motor Types	2- and 4-phase stepper motors, bipolar
Motor Current	0.1 to 1.5 A
Motor Resolution	50x microstep (20,000 steps/rev)
Trajectories	Trapezoid, linear interpolation, circular, helix
I/O	8 digital I/O lines, limit switch and reference signal
Analog input	2 channels
Interface	RS-232
Programming	MotionBasic development environment
Display	2x16 LCD display
Manual Input	24-key keypad
Operating Voltage	85-240 VAC, 50-60 Hz

Equipped with a high-performance, 32-bit processor and a multi-tasking operating system, all four axes can achieve step-for-step coordination and accuracy. The C-600 offers 2-D and 4-D linear, circular and helical interpolation, as well as the ability to operate simultaneously in more than one coordinate system. Together with high-precision stages like the M-511.2S, you can trace circles with radii of a few microns.

The C-600 can be operated using either the front-panel keypad or the serial port. The keypad functionality can be programmed by the user. The convenient MotionBasic development environment makes it possible for programmers and non-programmers alike to create simple program sequences and to download them to the C-600. Windows programmers can make use of the comprehensive function libraries for all Windows platforms. The MotionBasic development environment is a combination of a practical programming language with the G-code programming used for CNC machines.

All these features make the C-600 an extremely versatile controller which combines the advantages of a SPC system with the simplicity of a PC-programmable motor controller.

**HEADQUARTERS**

GERMANY  
Physik Instrumente (PI) GmbH & Co.  
Auf der Römerstrasse 1  
76228 Karlsruhe  
Tel: +49 (721) 4846-0  
Fax: +49 (721) 4846-100  
Email: info@pi.ws  
http://www.pi.ws

GERMANY  
PI Ceramic GmbH  
Lindenstrasse  
07589 Lederhose  
Tel: +49 (36604) 882-0  
Fax: +49 (36604) 882-25  
Email: info@piceramic.de  
http://www.pi.ws

GERMANY  
Berlin Sales Office  
Polytec - Physik Instrumente  
Vertriebs- und Beratungsbüro Berlin  
Schwarzschildstrasse 1  
12489 Berlin  
Tel: +49 (30) 6392-5140  
Fax: +49 (30) 6392-5141  
Email: piBerlin@pi.ws  
http://www.pi.ws

**SUBSIDIARIES**

USA West (Mexico)  
Polytec PI, Inc.  
1342 Bell Avenue, Suite 3A  
Tustin, CA 92780  
USA  
Tel: +1 (714) 850 1835  
Fax: +1 (714) 850 1831  
Email: info@polytepci.com  
http://www.polytepci.com

USA East (Canada)  
Polytec, PI, Inc.  
16 Albert St.  
Auburn, MA 01501  
USA  
Tel: +1 (508) 832 3456  
Fax: +1 (508) 832 0506  
Email: info@polytepci.com  
http://www.polytepci.com

JAPAN  
PI-Polytec Co., Ltd.  
2-38-5 Akebono-cho  
Tachikawa-shi  
Tokyo 190-0012  
Tel: +81 (425) 526 7300  
Fax: +81 (425) 526 7301  
Email: info@pi-polytec.co.jp

JAPAN  
PI-Polytec Co. Ltd.  
Hanahara Dai-ni Building, #703  
4-11-27 Nishinakajima,  
Yodogawa-ku, Osaka-shi  
Osaka 532-0011  
Tel: +81 (66) 6304 5605  
Fax: +81 (66) 6304 5606  
Email: info@pi-polytec.co.jp

GREAT BRITAIN  
Lambda Photometrics Ltd.  
Lambda House  
Batford Mill  
Harpending, Hertfordshire  
AL5 5BZ  
Tel: +44 (1582) 76 43 34  
Fax: +44 (1582) 71 20 84  
Email: info@lambdaphoto.co.uk  
http://www.lambdaphoto.co.uk

FRANCE  
Polytec PI S.A.  
32 rue Delizy  
F-93694 Pantin Cedex  
Tel: +33 (1) 48 10 39 30  
Fax: +33 (1) 48 10 08 03  
Email: pi.phot@polytec-pi.fr  
http://www.polytec-pi.fr

ITALY  
Physik Instrumente (PI) S. r. l.  
Via E. De Amicis, 2  
I-20091 Bresso (MI)  
Tel: +39 (02) 665 011 01  
Fax: +39 (02) 665 014 56  
Email: info@pionline.it  
http://www.pionline.it

**C-862 Mercury—the versatile DC-motor controller in a palm-top package**

Small in size but big in performance: this is the unique Mercury DC-motor controller. Introduced nine months ago, the Mercury became an incomparable sales success within a few weeks. This controller is the optimal solution in a wide variety of motion control and positioning applications. Up to 16 Mercury controllers can be daisy-chain networked off a single RS-232 port. This and the many other features make the Mercury the fastest and most inexpensive solution for a host of automation tasks.

**Have a look at these unique features:**

- Runs DC-Motors up to 6 watt with internal amplifier
- Runs DC-Motors up to 60 watt with external amplifier
- Compatible with all PI stages
- Speed up to 60 mm/s
- Extensive command set
- P-I-D servo control
- Non-volatile storage of all system parameters

- Macro programmable
- Non-volatile storage of macros and parameters
- Autostart option to run a motion program at power-up without PC
- Digital I/O ports for internal / external triggering
- Inputs for limit and position reference sensors
- Output for control of motor brakes

- Operation with and w/o PC
- Communication via RS-232 interface
- Networkable, with up to 16 Mercurys off one single RS-232 port
- Single-voltage operation, 12-15 VDC
- Extensive software for operation and programming, libraries for all Windows OS, LabView drivers



C-862 Mercury II: Network address settable by dip switches without opening the case

The Mercury was developed for the OEM market with high volume, high performance and low price in mind. Now the Mercury is also available in small quantities at a very reasonable price level. The package also includes a wide-range power supply, RS-232 cable, software and user manual.

**More information about Mercury controllers can be found in the new PI Product Catalog on page 9-10. Or call PI and talk with one of our sales engineers.**

## M-501 a vertical stage for M-500 series

In the past, if you needed precise vertical motion and did not enough room to install a linear translator at a 90-degree angle, then you had a problem that could not be solved without sacrificing precision. Now, PI is offering the M-501.1PD,

products and is sized for direct mounting on the M-511, M-521 and M-531 platforms (no adaptor plate required!).

a vertical stage for the M-500 series. The M-501 meets the high standards that we and our customers expect from our

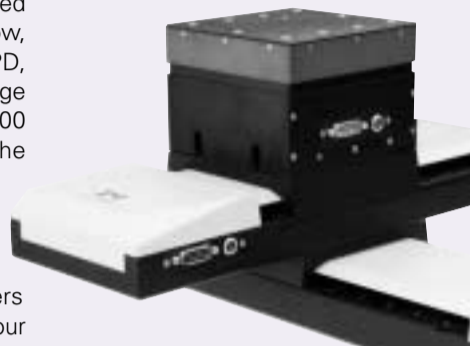

### Technical Data

Travel range	12.5 mm
Max. holding force	20 N
Design Resolution	0.008 µm
Min. Incremental Motion	< 0.1 µm
Unidirectional repeatability	< 0.1 µm
Backlash	< 1 µm
Max. velocity	15 mm/s
Angular runout	300 µrad
Dimensions	130 x 130 x 88 mm (103 mm at max. extension)

The **new M-331 to M-333** series offers a wide range of travel ranges and stage sizes for the widest variety of applications. They are based on the proven design of the M-105.

Of course, individual stages of the same size can easily be combined in any combination. In addition, any stage can be mounted on the next-larger stage without an adapter plate.

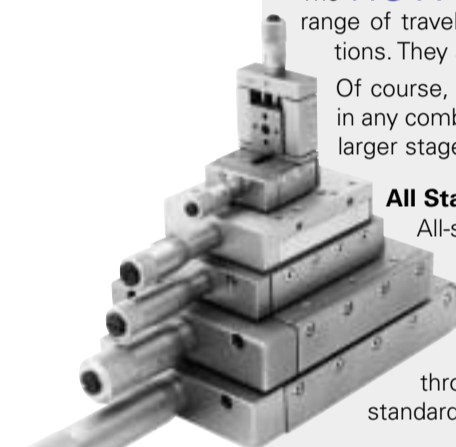

### All Stainless-Steel

All-stainless-steel construction and homogenous materials for the base, carriage, crossed roller bearings, guides and drive assure a maximum of stability and guiding accuracy, even under conditions of varying temperature.

In addition, the stages have a central open aperture throughout the entire travel range, a feature which is hardly standard on crossed-roller-bearing steel stages.

### High Variety of Drives

PI offers the following alternative drives for most of the stages:

- Differential micrometers for manual positioning with 0.1 µm resolution.
- Motorized micrometer drives, the DC-Mikes, for automated tasks for resolutions better than 1 µm.
- Piezoelectric hybrid drives, the PiezoMikes, for even higher resolutions. PiezoMikes offer a "coarse" range of several millimeters and a fine range of 30 µm with a flexure-guided piezoelectric drive.

### Alternatives in Aluminum

For applications where temperature changes are not an issue, versions will soon be available with aluminum bodies and carriages. Their advantage over their steel counterparts of the same size and travel range lies in their lower cost.

## Top precision now also available for shorter ranges

The M-505 now rounds out the M-500 series with travel ranges of 25, 50, 100 and 150 mm (1-6 in.). The result is a uniform series of models in varying sizes up to 300 mm (12 in.) travel range.

All the stages share the same degree of precision, and:

- Compact, low-profile design with integrated motor
- Recirculating ballscrew drive for speeds of up to 50 mm/s or continuous operation
- Hall-effect reference and limit switches
- Active Drive™ motor option
- Stepper motor option

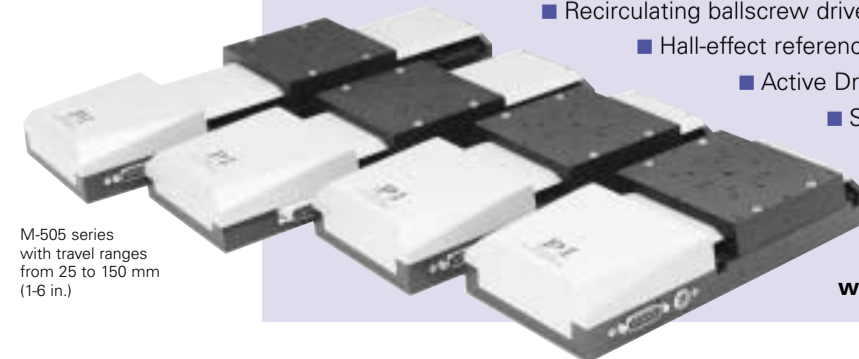

M-505 series with travel ranges from 25 to 150 mm (1-6 in.)

The M-505 series was designed for industrial use and is specified with an MTBF of > 20,000 hours. You can learn more about this product in our catalog, *MicroPositioning, NanoPositioning, NanoAutomation*, p. 7-38, or by visiting [www.pi.ws](http://www.pi.ws)

## FIND PI AT

**Photonics West, San Jose, CA (USA)**  
January 22-24, 2002

**Biophysical Society 46<sup>th</sup> Annual Meeting, San Francisco**  
February 24-26, 2002

**OFC, Anaheim, CA (USA)**  
March 19-21, 2002

**Sensors, San Jose, CA (USA)**  
May 21-23, 2002

**CLEO, Long Beach, CA (USA)**  
May 21-23, 2002

**Semicon West, San Francisco, CA (USA)**  
July 22-24, 2002

**NFOEC, Dallas, TX (USA)**  
September 17-18, 2002

**Diskcon, San Jose, CA (USA)**  
September 18-19, 2002

**Euspen in Eindhoven (NL)**  
May 26-30, 2002

**INFMeeting 2002 in Bari (Italy)**  
June 24-28, 2002

**BIAS 2002 in Milan (Italy)**  
November 19-23, 2002

**Drives & Controls in London (UK)**  
March 13-15, 2002

**Photonex in Coventry (UK)**  
October 17-18, 2002

**Hannover Messe (Germany)**  
April 15-20, 2002

**Semicon Europe in München (Germany)**  
April 16-18, 2002

**Fiber Communication in München (Germany)**  
June 4-6, 2002

**Actuator in Bremen (Germany)**  
June 10-12, 2002

**Optatec in Frankfurt (Germany)**  
June 18-21, 2002

**electronica in München (Germany)**  
November 12-15, 2002

**Photonics Korea 2002, Seoul (Korea)**  
September 2002

At last!

## PI Headquarters has moved

Thirty-five hundred truckloads of earth and exactly one year of construction later, in October 2001, PI's new headquarters building in Karlsruhe was virtually completed and finally occupied. The move also involved 70 moving-van loads for the manufacturing department alone, and an indeterminate volume of champagne.

We now have 5700 square meters (61,300 sq. ft.) for administration, sales, development, and training alongside 7000 square meters (75,300 sq. ft.) for production. The production area can be doubled at a later date simply by remodeling existing undeveloped floorspace.

### The new headquarters address is:

Physik Instrumente (PI) GmbH & Co.  
Auf der Römerstrasse 1 · 76228 Karlsruhe, Germany  
Telephone: +49-7 21-48 46-0 · Fax: +49-7 21-48 46-100  
E-mail: [info@pi.ws](mailto:info@pi.ws) · Web: [www.pi.ws](http://www.pi.ws)



New PI headquarters

## Rotary stages with a new look

Introducing the new M-060, M-061 and M-062 rotary stages. These stages are equipped with a preloaded worm-gear drive to virtually eliminate backlash. The standard versions also have direction sensing and a non-contact Hall-effect reference switch which allows connection to the C-880 multi-axis motion controller. All PI motor types are available, from stepper motors, DC servo-motors to the optional ActiveDrive™ with IntelliStage™ compatibility.

The stages of the series have different platform diameters: 60 mm for the M-060, 90 mm for the M-061 and 120 mm for the M-062. The M-062 is also available with a direct position feedback option, implemented by attaching the encoder directly to the rotor.

You can learn more about this product on p. 7-60 of our catalog, or by visiting [www.pi.ws](http://www.pi.ws)



M-060, M-061 and M-062 rotary stages



P-244 / P-255 piezoelectric actuators in the described application. The actuators are provided with water-resistant cases and clean-air connections for protection against the environment (grinding dust, water vapor, oil aerosols).

## Using piezo translators for parallax error correction in precision grinding

High-precision mechanical parts—especially parts in modern internal combustion engines—must be produced with very low tolerances. To meet these requirements, turned parts must be ground in a follow-up operation. During grinding, the grinding wheel rotates at high speed while the cylindrical part is rotated slowly. This process is generally plagued by an undesirable non-zero angle between the workpiece axis and the grinding wheel axis.

The effect of this angle can be corrected as follows: First, a blank is ground and its deviation from a perfect cylinder is measured (parallax error). This error is then corrected using the appropriate micrometer screw.

The problem is that it is not possible to read out sub-micron settings with a micrometer screw, so numerous blanks have to be run in order to find the right position.

Here the advantages of piezoelectric translators can be used: with up to 0.2 mm travel range and high stiffness (several hundred newtons per micron), a piezo can resolve positions in the nanometer range. Linked to sensors, the piezo can move to within a few nanometers of a defined position repeatedly. This means that production can begin immediately after the first blank is measured and the piezo translator correspondingly initialized.

In this application, the piezo translator saves both time and material.

## PUBLISHER

Physik Instrumente (PI) GmbH & Co. KG  
Römerstrasse 1 · 76228 Karlsruhe, Germany  
Responsible for the contents: Dr. Karl Spanner  
Editorial staff: Steffen Arnold  
Production: Systemmedia, Pforzheim, Germany  
Reproduction: in accordance with publisher, references required.  
Further information on request.

## Piezo stages with E-710 digital control electronics

The P-500 series has grown into a well-rounded collection of multi-axis piezo stages. They have the same dimensions but different combinations of active axes, with up to 6 degrees of freedom. The optimal stage for a specific application can be chosen from what are now 18 different models. Seventeen variants are described in detail in our 2001 catalog.

The resonant frequency and stiffness of the various system axes vary considerably from model to model. The exact values are cited in the catalog. Turn to your PI sales engineer for help in choosing the optimum system for your application.

### Increased performance with digital control

Optimum performance of the P-500 stages is achieved with the use of an E-710 digital controller.

With the digital controller, the advantages of the single-module design can be fully realized and step-and-settle controlled in all dimensions at once. Not only can complex trajectories be realized, but thanks to rapid sensor data transfer and high controller calculation speed, any cross-talk effects can be effectively compensated. For example, by adding Z-axis control, out-of-plane motion accompanying XY moves can be reduced.

The E-710 can optionally be equipped with an ultra-fast PIO (parallel input/output) interface. With a data rate of 1 read or write operation per microsecond, the PIO provides data virtually in real-time. Such data can include, for example, readout of position values or input of signals from a function generator (for scanning applications) or target positions generated by an external servo-loop.

For scanning applications, the E-710.SCN software option is a cleverly thought out addition designed to move a multi-dimensional piezo cap-sensor stage (P-500 series, P-733, etc.) along a scan line. Using a learning function, the operating voltages are so controlled (Signal-Preshaping™) that the stage motion exactly follows the scan lines. The great advantage here is that the system figures out the optimal servo-control parameters (which vary according to load, etc.) all by itself.

Even without the function-generator software option, optimal servo-loop parameters can be entered using the standard NanoCapture™ software.



P-5876CD six-axis NanoPositioner with E-710.6CD digital electronics

### E-710 general data

Processor	DSP 32-bit floating point, 50 MHz
Sampling rate	40 µs sensor 200 µs servo-loop on all channels
Effective resolution of D-to-A converter	20 bits
Max. output power	25 W per channel
Average output power	6 W per channel
Max. output current <20 ms	200 mA per channel
Average output current >20 ms	50 mA per channel
Output voltage range	-20V to +120V

### E-710 digital electronics model overview

**E-710.4CL** 4-channel controller with LEMO connectors

**E-710.3CD** 3-channel controller with sub-D connectors for ID-chip readout

**E-710.4CD** 4-channel controller with sub-D connectors for ID-chip readout

**E-710.6CD** 6-channel controller with sub-D connectors for ID-chip readout

**E-710.P3D** 3-channel controller with sub-D connectors and PIO Interface

**E-710.P4D** 4-channel controller with sub-D connectors and PIO Interface

**E-710.SCN** Software Option Internal function generator with learning function for scanning applications

Systems with a multi-axis positioner or scanner like the P-500 find application in: Microscopy / scanning microscopy: SNOM, AFM, E-beam (P-500 vacuum version). Semiconductor: mask positioning, vertical wafer positioning, wafer stepping. Biotechnology, Medicine: cell tracking, microscopy, interferometry, surface profile mapping. Stages available for such applications include vacuum versions and, on request, non-magnetic versions.



P-527.2CL single-module XY NanoPositioner

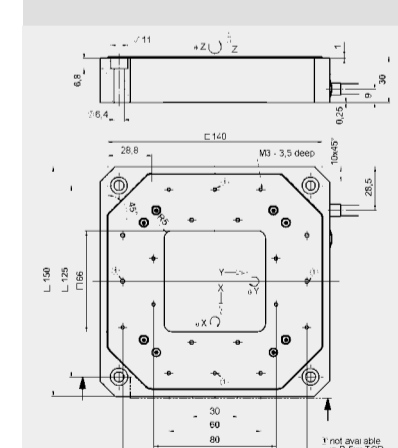

P-527 dimensions, in mm

### P-500 series general data:

	X	Y	Z	θ <sub>x</sub>	θ <sub>y</sub>	θ <sub>z</sub>
Travel range up to *	200 µm	200 µm	200 µm	+/- 1 mrad	+/- 1 mrad	+/- 2 mrad
Repeatability up to *	+/- 1 nm	+/- 1 nm	+/- 1 nm	+/- 0.1 µrad	+/- 0.1 µrad	+/- 0.5 µrad

\* In multi-axis P-500 models, it is not always possible to achieve these values on all axes at the same time.

### P-527.6CD six-axis positioner and scanner data:

	X	Y	Z	θ <sub>x</sub>	θ <sub>y</sub>	θ <sub>z</sub>
Travel range	200 µm	200 µm	20 µm	+/- 0.3 mrad	+/- 0.3 mrad	+/- 2 mrad
Repeatability	+/- 10 nm	+/- 10 nm	+/- 5 nm	+/- 0.1 µrad	+/- 0.1 µrad	+/- 1 µrad